



**SOUND TRANSIT**

**HCT Planning**

## **East Corridor HCT – Summary of I-90 Floating Bridge (Homer Hadley) Studies**

*Prepared for:*  
Sound Transit

*Prepared by:*  
Parsons Brinckerhoff Quade & Douglas, Inc.

# **Final**

March 2006

# Table of Contents

<b>1.</b>	<b>Introduction.....</b>	<b>1</b>
<b>2.</b>	<b>I-90 Floating Bridge (Homer Hadley) Studies.....</b>	<b>1</b>
2.1	<i>I-90 Floating Bridge Analyses:.....</i>	<i>1</i>
2.2	<i>I-90 Floating Bridge Test (2005).....</i>	<i>2</i>
2.3	<i>Comparison of I-90 Floating Bridge to Existing Comparable Rail Bridges .....</i>	<i>2</i>
<b>3.</b>	<b>Future Design Considerations for Rail Joint and LRT Operations.....</b>	<b>8</b>
<b>4.</b>	<b>Summary.....</b>	<b>9</b>

<b>Attachment A: Chronological Summary of I-90 Floating Bridge Structures and Rail Joint Issues on Homer Hadly I-90 Floating Bridge .....</b>	<b>A-1</b>
---	------------

<b>Attachment B: SkyTrain Cable Stayed Bridge (Skybridge) Rail Joint - Additional Photos .....</b>	<b>B-1</b>
--	------------

<b>Attachment C: AREMA Technical Paper - <i>Design of Continuous Welded Rail on a Suspension Bridge, 2000, Ranganatha R,Rao and Sudhir Sanghvi.....</i></b>	<b>C-1</b>
---	------------

# 1. Introduction

This report summarizes previous studies conducted on the I-90 (Homer Hadley) floating bridge relating to potential future light rail transit operations, identifies major issues related to the design of a transition rail joint, and correlates these prior work efforts with the recent I-90 floating bridge tests conducted by WSDOT/ Sound Transit. It includes discussion of:

- The assumptions and assessments from prior rail joint studies, as well as design and operational elements to be considered in the design of a rail joint for the I-90 floating bridge structure;
- The operational assumptions for light rail vehicle type;
- Proposed track configurations;
- The associated bridge movements expected at the transition between the floating bridge and the transition structures; and
- Floating bridge mitigation measures to address light rail transit operations across the bridge.

## 2. I-90 Floating Bridge (Homer Hadley) Studies

Since 1985, multiple studies have been conducted to assess the feasibility of operating light rail on the I-90 floating bridge. These studies include an assessment of alternate loading scenarios, anticipated movement of the roadway structures, and consideration of the rail joint at the floating bridge and transition structure spans. A chronological summary of the key studies, as well as the documentation prepared as part of these studies, is presented in Attachment A.

### 2.1 *I-90 Floating Bridge Analyses:*

In 1985, design criteria for the new floating bridge were developed. The original WSDOT design considerations included design criteria for rail transit loading on the floating bridge.

Following the completion of the new I-90 Floating Bridge, the feasibility of running light rail transit on the newly constructed floating bridge was reassessed. Various track types and roadway configurations were studied to determine the effects on the floating bridge, including loss of freeboard and how to accommodate the movement of the expansion joint within the track design across the bridge. The technical memorandum prepared by Parsons Brinckerhoff/ Kaiser Engineering Team in 1991 *Use of I-90 Floating Bridge for Rail Transit Technical Memorandum Draft November 11, 1991* summarized this work, which indicated that there were no fatal flaws associated with incorporating LRT facilities on the I-90 Floating Bridge. The memorandum included a previously developed schematic of a design solution for the rail joint. This schematic rail joint is able to accommodate the required floating bridge movements included in the original design criteria.

In 2001 a KPFF report *Homer Hadley Interstate 90 Floating Bridge – Draft Structural Feasibility Study: Light Rail Conversion, September 2001* documented analytical studies of the movements of the floating bridge and at the expansion joints on the transition spans.

It was noted that trackwork, overhead contact system (OCS), maintenance walkway/cable tray and miscellaneous guideway elements increase the dead weight on the bridge and would reduce the existing freeboard. Alternate rail systems and rail positions were also investigated due to the sensitivity of the floating bridge to added weight (*KPFF Report, September 2001*). It was found that loss of freeboard is more sensitive to the rail system type than rail location. Because of this, the WSDOT analysis currently assumes continuous welded rail (CWR) with direct fixation track on doweled concrete single fastener plinth with restraining rail to reduce the dead load on the bridge.

The following bridge movements were identified in the 2001 KPFF report:

- Longitudinal Movement: +/- 2'-0.5"
- Horizontal Rotation: +/- 1.1 deg.
- Vertical Rotation: 2.2 degrees (downward)
- Loss of Freeboard due to Dead Load: approx 5 inches

Attachment A further details the studies and discussions carried out from 1985 to 2005.

## **2.2 I-90 Floating Bridge Test (2005)**

In September 2005, the I-90 bridge tests were conducted to simulate LRT live loading, by driving flatbed trucks loaded with the approximate total gross weight of LRT vehicles across the I-90 bridge to simulate light rail operations. The actual movements of the bridge were measured using sensors placed in five locations on the west half of the bridge. Methodology and results of the study were included in the WSDOT report entitled *Homer Hadley Interstate 90 Floating Bridge Test Program for Light Rail Transit Draft Test Report November 14, 2005*.

The test results correlated with the movements predicted previously using analytical methods (as reported in 2001 by KPFF) and therefore verified that it was acceptable to use the developed analytical methods to study the response of the bridge to LRT live loading.

## **2.3 Comparison of I-90 Floating Bridge to Existing Comparable Rail Bridges**

In a memorandum to Sound Transit from Puget Sound Transit Consultants (PSTC) dated October 4, 2001, PSTC identified examples of modern rail bridges that have rail joints designed to accommodate similar movements to those expected for the I-90 floating bridge. The two bridges were: Tagus River Suspension Bridge (Lisbon, Portugal) and the SkyTrain Cable Stayed Bridge (Skybridge) across the Fraser River (Vancouver, B.C., Canada), both of which have a successful history of passenger rail operation.

Table 1 below provides a comparison of these bridges by movement type: longitudinal movement, horizontal rotation and vertical rotation. Movements on the Tagus River Suspension Bridge (Lisbon, Portugal) exceed those expected on the I-90 floating bridge and movements on

the SkyTrain Cable Stayed Bridge (Vancouver, B.C., Canada) are slightly less than those expected on the floating bridge.

Horizontal rotation was not specified for the Tagus River Bridge or Skybridge; however changes in horizontal rotation due to temperature or live loading translates into additional longitudinal movement and slight horizontal rotation of the rail. It is expected that even though the horizontal rotation is not specified for either joint, they actually accommodate horizontal rotation similar to those that would occur on the I-90 Floating Bridge.

The October 2001 memorandum from PSTC reported that rail joints developed by others for both the Tagus River Suspension Bridge and SkyTrain Cable Stayed Bridge are currently operating for movements of similar magnitudes to those anticipated for the I-90 floating bridge. The memo concluded that a joint design for the I-90 Floating Bridge could be developed.

**Table 1 Summary of Bridge Movements Identified in Previous Studies**

Movement	I-90 Bridge (modeled) <sup>1</sup>	Tagus River Bridge (Lisbon Portugal) <sup>2</sup>	Skybridge (Vancouver Canada) <sup>2</sup>
Longitudinal Movement (Includes extra movement required for horizontal rotation)	+/- 2'-0.5"	+/- 5'-0"	+/- 1'-1.1"
Horizontal Rotation (Rotation of transition span due to its transverse displacement at floating bridge)	+/- 1.1 deg.	Not specified <sup>3</sup>	Not specified <sup>4</sup>
Vertical Rotation (Rotation of transition span due to its vertical displacement at floating bridge)	2.2 degrees (downward)	+/- 3.43 deg	+/- 0.75 deg

<sup>1</sup> Fax from KPPF to PSTC March 16, 2001

<sup>2</sup> Memorandum from PSTC to Sound Transit October 4, 2001

<sup>3</sup> The AREMA technical paper *Design of Continuous Welded Rail on a Suspension Bridge, 2000, Ranganatha R.Rao and Sudhir Sanghvi* does not specifically mention provision for horizontal deflection and the angular change at the joint between the anchorage and the 323.5 foot backstay spans which would be caused by transverse horizontal loads such as wind or seismic. It is possible that a similar joint assembly would be able to accommodate the 1.1 degree floating bridge joint requirement with appropriate modification (see Memorandum from PSTC to Sound Transit October 4, 2001)

<sup>4</sup> The memorandum from PSTC to Sound Transit October 4, 2001 states "based on the bearing and joint design criteria. The criteria specified 0.20" (5mm) gap between bearing guidebars."

### Skybridge (Vancouver, B.C., Canada)

Due to temperature, wind and live load, the Skybridge rail joint undergoes vertical and horizontal angular changes and longitudinal movement. The Skybridge rail joint consists of two parts:

1. A 13ft to 14.5ft (4m to 5m) long section of track on the fixed section of the bridge transition structure, consisting of the sliding rail joint which allows for a longitudinal movement of the rail (refer Figure 1 and Figure 3 below). The sliding rail joint consists

of two separate rails, one rail that is a standard shape and slides along the side of the adjoining rail, the adjoining rail tapers to a point and is fixed. The tapered fixed rail enables a smooth transition for the train wheel across the joint accommodating longitudinal movement in the rail. This joint also accommodates horizontal rotation that results in longitudinal movement.

2. A 13ft to 14.5ft section straddling the bridge expansion joint, consisting of ten tie plates, each with two spring devices that enable the rail joint to undergo vertical angular change (refer Figure 1 and Figure 2 below).

**Figure 1. Diagrammatic Representation of the Skybridge Rail Joint Movements**

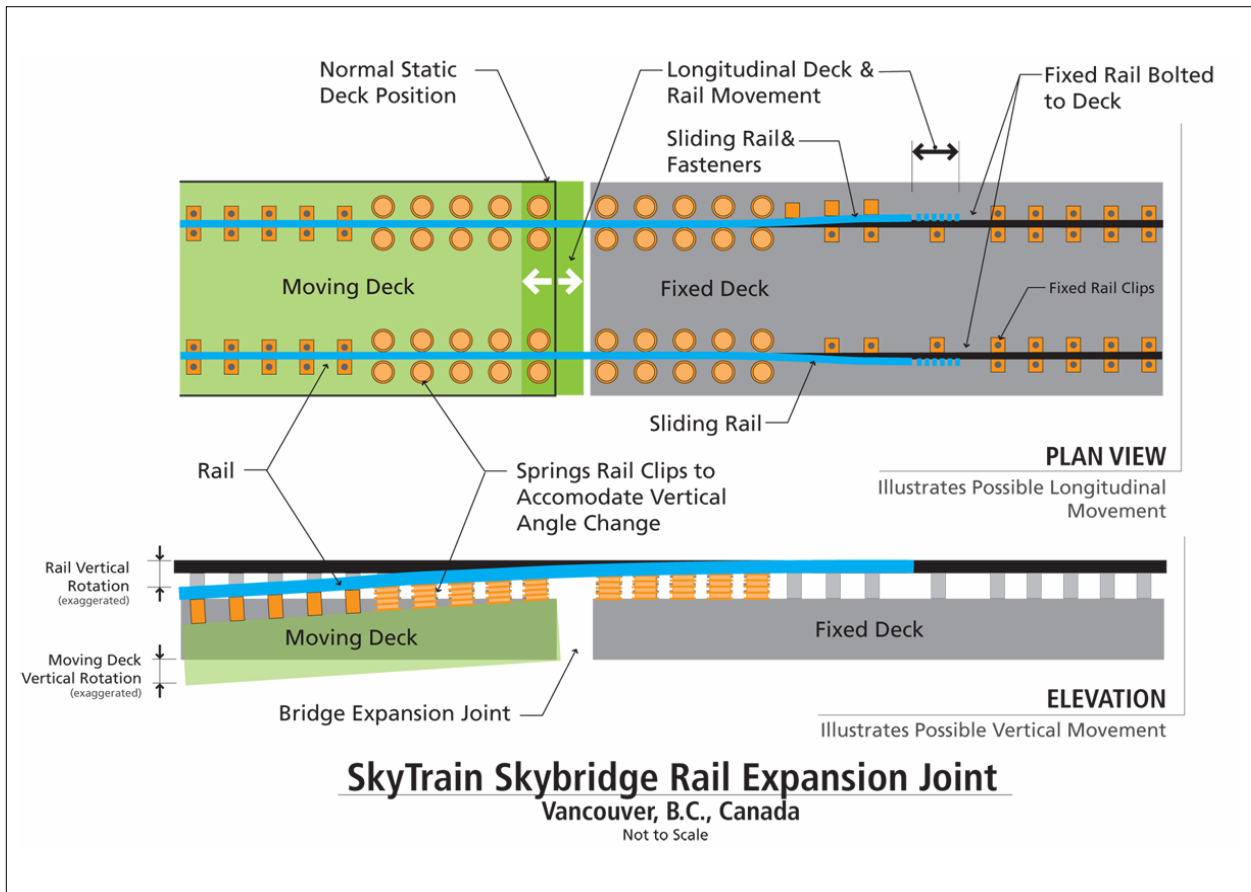

**Figure 2. Vertical Adjustment Section of the Skybridge Expansion Joint**

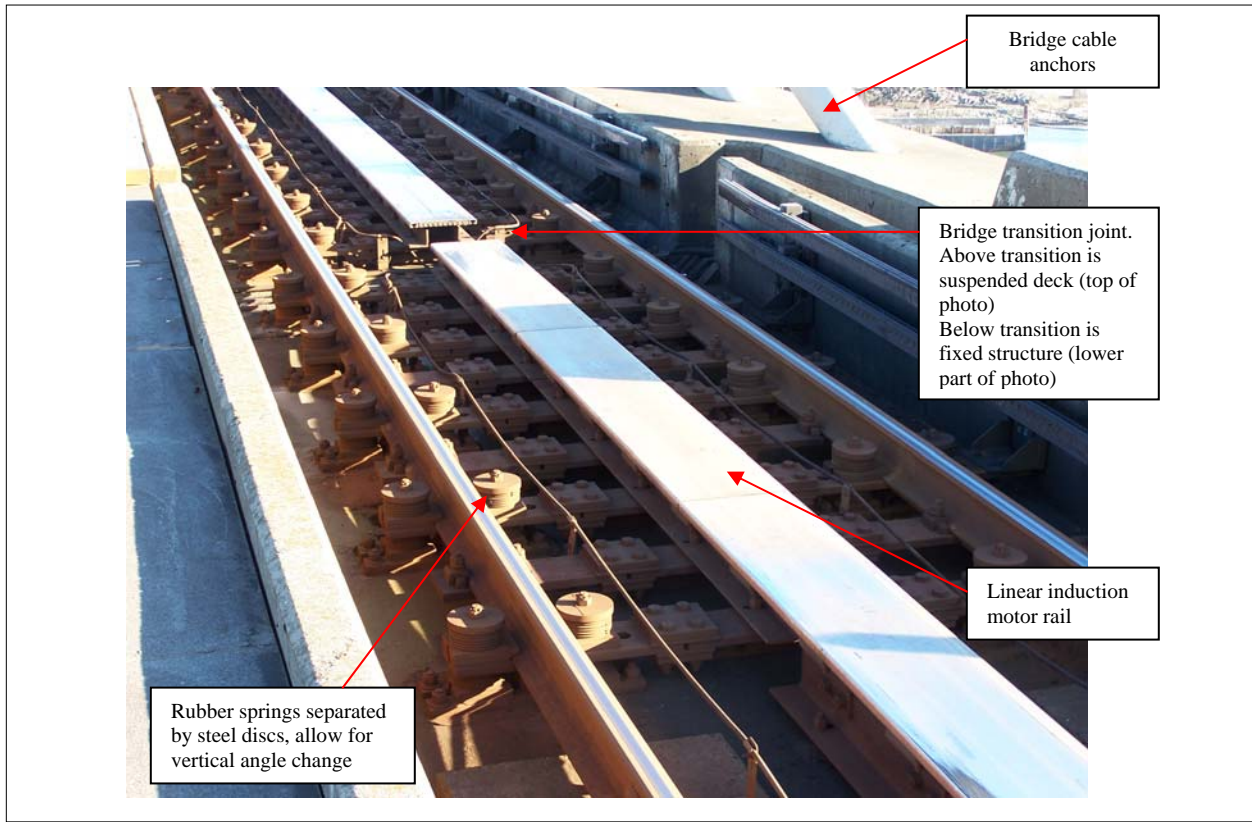
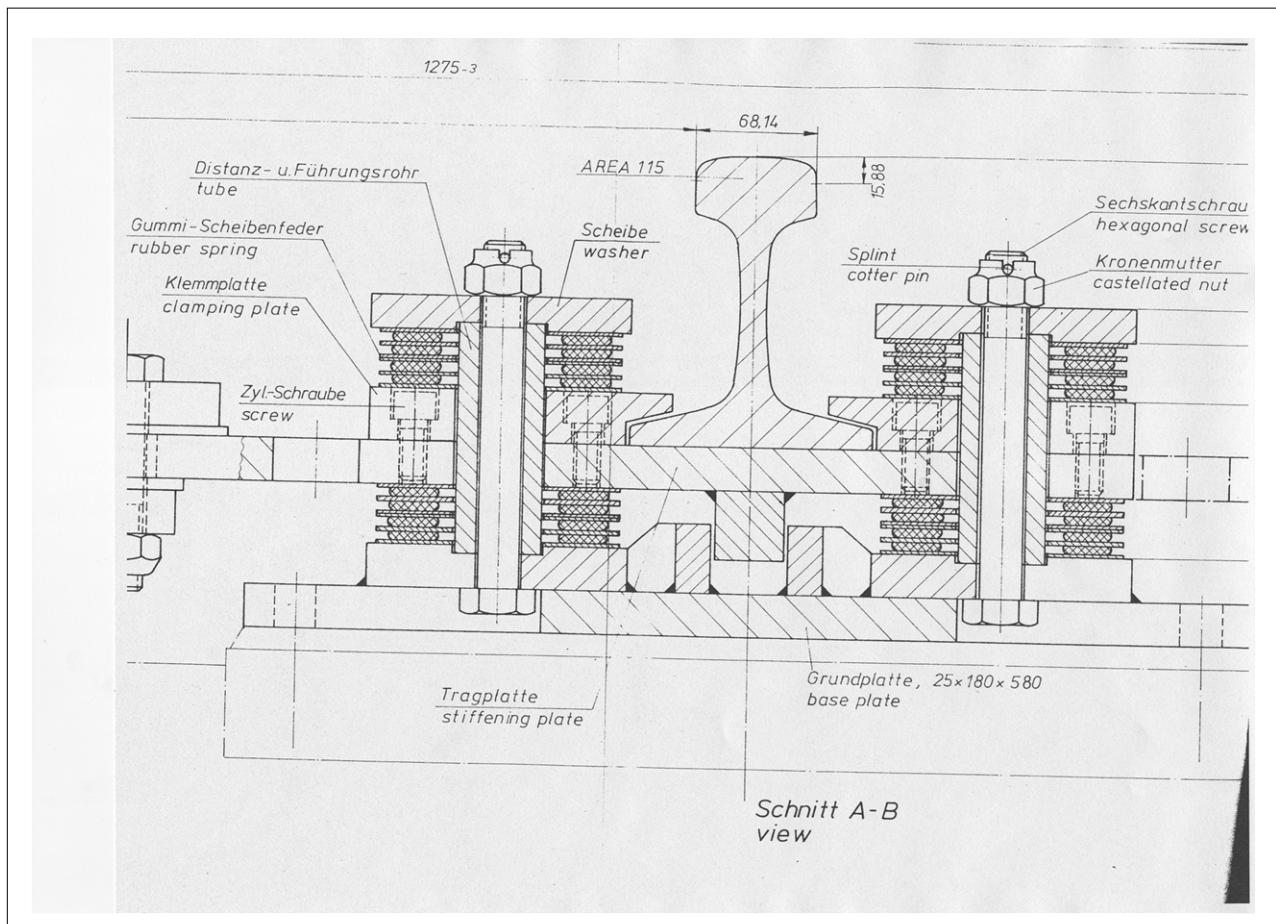

**Figure 3. Fixed Side of the Rail Expansion Joint (matches to bottom of Figure 1)**



Figure 2 identifies rubber springs that are separated by steel discs attached to each of the tie plates. Over the joint there are 10 tie plates each with two spring devices. Figure 4 below details the rubber spring and rail configuration. Underneath each base or tie plate, different types of polyurethane grout have been injected. This grout changes volume under compression and helps facilitate a smooth transition for the rail over the expansion joint as the bridge moves vertically. The rail moves longitudinally as well between the two spring systems.

**Figure 4. Extract from Skybridge drawings detailing the Rubber Spring and Rail Configuration**



The total length of the rail joint is 39 ft (11.9m). SkyTrain staff confirmed that the Skybridge rail joint has been in operation for approximately 16 years and no adverse operation or maintenance issues have been encountered for the rail joint over this period of time.

Attachment B contains additional photos of the rail joint on Skybridge, the cable stayed SkyTrain Bridge across the Fraser River (Vancouver, B.C.).

### Tagus River Bridge (Lisbon, Portugal)

Attachment C contains the AREMA technical paper *Design of Continuous Welded Rail on a Suspension Bridge, 2000, Ranganatha R. Rao and Sudhir Sanghvi*. The following is a brief summary explanation of the Tagus River Bridge rail and expansion joint configurations as discussed in the attached technical paper. Key points and some direct text from the paper has

been used in the following summary of *Design of Continuous Welded Rail on a Suspension Bridge, 2000, Ranganatha R. Rao and Sudhir Sanghvi.*

The Tagus River suspension bridge in Lisbon, Portugal was originally built to carry four lanes of traffic on the upper deck level with design provision for a second phase construction to allow for future railroad track installation at the bottom cord of the truss below. The bridge has since been retrofitted to add two railroad tracks at the lower level and widen the upper deck to accommodate six lanes of traffic.

The expansion assembly consists of moving telescopic girders mounted on vertical rollers and restrained by horizontal rollers between the stationary girders. Longitudinally split track rails are mounted on these girders. Split rails are L-shaped rails and are illustrated in Figure 12 Section C of Attachment C. The tip of the rail facing the direction of rail traffic is specially shaped to transfer the rolling wheel smoothly to the adjacent split rail (this is similar to the slip rail joint described above for the Vancouver Skybridge).

Across the bridge the track layout is divided into different zones (refer to Attachment C, Figure 3 which illustrates each of the rail track zones):

- Standard zone (also the rail slip zone)
- Anchor zone
- End zone
- Expansion zone
- Creep free zone

The standard zone consists of continuous welded rail. The track in this zone deflects as required to suit the suspended truss. The anchor zone is at the end of the bridge and is where the continuous welded rail terminates and is anchored through an anchor joint where the rail is rigidly connected in the longitudinal direction. The end zone is the short section of track between the anchor joint and the expansion joint structure. The expansion zone contains the expansion assembly structure. Following this is the creep free zone which protects the expansion structures and stops any longitudinal movements.

The thermal expansion of the truss is significant and the truss ends move in and out due to the deflection of the truss under live load. If the running rail is rigidly fixed this would result in a kink in the rail and high bending and fatigue stress, therefore the rail is mounted such to allow for the rail base to adjust to the imposed curvature of the truss. To deal with the required movements of the running rail, a unique expansion assembly structure was developed for the Tagus River Bridge.

The expansion joint has two functions; longitudinal movement and dispersion of angular bend. The expansion structure consists of the following components (refer to Attachment C, Figures 9, 10, 11 and 12 which illustrate each of the joint components):

- Transition girder and telescopic girders
- Split rails for rail expansion
- Check rail and its expansion arrangements
- Angular bend dispersion components

- Telescopic girder mountings

The transition girder is inserted between two stationary telescopic girders and held laterally and rigidly by two horizontal rollers. The split rails are mounted on the stationary and moving girders back to back. The check rail expansion is continuous over the expansion gap and is extended from the truss over the telescopic girder and expansion joint up to the approaches to provide lateral restraint to the wheel.

Double track and expansion joint units were successfully installed and open to rail on the Tagus River Bridge in July, 1999.

### 3. Future Design Considerations for Rail Joint and LRT Operations

The following are design considerations that should be considered during design of the I-90 floating bridge for LRT operation. These design considerations are based on Link Light Rail Design Criteria, the KPF reports *Homer Hadley (Interstate 90) Floating Bridge – Draft Structural Feasibility Study Light Rail Conversion September, 2001*, and *Homer Hadley Interstate 90 Floating Bridge Test Program for Light Rail Transit Draft Test Report November 14, 2005*.

#### Design Criteria:

- For vehicle load requirements adopt the LRT design vehicle load as per Fig. 8.1 of the Link Light Rail Design Criteria.
- Dead loads for single-fastener plinth design with restraining rails to be taken from KPF September, 2001 report (see Attachment A).
- It should be noted that design of the I-90 floating bridge considered HS20 loading which is a lighter design load than the current standard HS25 loading. As part of the WSDOT test program (see *Homer Hadley Interstate 90 Floating Bridge Test Program for Light Rail Transit Draft Test Report November 14, 2005*) WSDOT concluded that the strength and serviceability criteria for pontoon global response are met at mid-span and at the far west end of the bridge for live loading due to two tracks of Sound Transit's LRT system in combination with HS25 traffic on the westbound roadway. WSDOT also concluded that a comprehensive analysis of all remaining pontoons of the bridge should be done during final design.
- Adopt WSDOT criteria to keep bridge in trim and maintain zero net freeboard loss after addition of rail system components.
- The light rail vehicle location on the I-90 Floating Bridge is to be as per LR(mod) rail system at track location 3 as detailed in the KPF September, 2001 report (LR(mod) at location 3 represents the terminology used to represent the rail system designation and the location as detailed in the September, 2001 report).

#### Mitigation measures required to maintain zero net freeboard loss:

(As per KPF September, 2001 and November, 2005 reports and the WSDOT December 15, 2005 *Board Briefing on the I-90 Bridge Studies*)

- Removal of existing south concrete barrier and replacement with cable railing.
- Removal of auxiliary ballast within the floating bridge pontoon cells.

- Removal of one inch of the existing concrete overlay on the south side of the concrete median barrier and replacement with ¼ inch of polymer concrete overlay.
- Remove auxiliary ballast.
- Limit location of rail on bridge deck; accommodates fourth westbound traffic lane.
- Addition of buoyancy is not included in mitigation.

Additional Design and Operational Considerations:

- Fatigue in the rail fastening systems, resulting from differential deflection between the bridge structure and rail, may require use of rigid clips and fastenings at the joint.
- Rail Convertible Bus Rapid Transit (RC BRT) and LRT operation scenarios are currently under considerations along the I-90 corridor.
- Joint (dual) operation of LRT vehicles and buses on I-90 structure is not contemplated in the center roadway.

## 4. Summary

The live load test carried out by WSDOT in 2005 (*Homer Hadley (Interstate 90) Floating Bridge Test Program for Light Rail Transit Draft Test Report November 14, 2005*) validated the previous 2001 WSDOT computer model results (*Homer Hadley (Interstate 90) Floating Bridge – Draft Structural Feasibility Study Light Rail Conversion September 2001*). Based on this analysis, WSDOT concluded that it is feasible for the I-90 Floating Bridge approach and transition structures to support the increased loading for LRT. A reduction in dead weight is required in order to mitigate freeboard loss due to light rail loading. The WSDOT studies also provide information about the anticipated movements of the I-90 bridge with light rail. Comparison of the anticipated movements on the I-90 bridge relative to movements of other existing, modern rail bridges demonstrate that it is feasible to design a rail joint to accommodate the movements of the I-90 Floating Bridge across the existing joints. Design of the joint will be developed in project level analysis if light rail is selected as the preferred mode for the East Corridor HCT alignment.

## **Attachment A: Chronological Summary of I-90 Floating Bridge (Homer Hadley) Structures and Rail Joint Issues**

Review of prior reports, technical memoranda, meeting notes, and correspondence related to the floating bridge studies identified the following documentation related to rail joint issues, design criteria, bridge loadings, LRT feasibility studies, joint movements, and load tests:

- 1985: METRO “Multi-Corridor Project” issued Working Paper, Task A.4.b – *Analysis of the Third Lake Washington Floating Bridge for Selection of the Light Rail Transit Vehicle and Its Effects on the Structures May 15, 1985* which studied the selection of LRVs and suggested design criteria for the third floating bridge. No specific track joint issues were included.
- 1985: Tudor Engineering Company performed a structural analysis for proposed LM Transit Lanes (LM defines the geometric center line of the center roadway on I-90). The analysis was based on AASHTO live loading and an assumed design LRT vehicle (the heaviest LRV currently available). Analysis addressed Phase II construction and analysis of approach spans and transition spans.
- 1991: Parsons Brinckerhoff/ Kaiser Engineering Team Draft Report *Use of I-90 Floating Bridge for Rail Transit Technical Memorandum Draft November 11, 1991* studied rail on I-90 with joint bus use. Includes 1986 rail joint concept by John Williams in Appendix B of the 1991 report.
- 2000: PSTC transmitted the 1985 and 1991 report documents to WSDOT.
- 2001: Considerable work for the TransLake Study by the Puget Sound Transit Consultants (PSTC) and for WSDOT specific to the floating bridge and by KPFF in the report, *Draft Structural Feasibility Study Light Rail Conversion September 13, 2001*. Technical topics include:
  - Effect of Dead Loads
  - Joint Movements
  - Structural Feasibility of LRT Conversion
  - Comparison of I-90 Floating Bridge movements to the Tagus River (suspension) Bridge and the SkyTrain (cable stayed) Bridge (PSTC memo to ST re: Translake Washington Project, October 4, 2004)
- 2003: Miscellaneous discussion as documented in emails between ST, PSTC, and WSDOT regarding design criteria, assumptions and LRT conversion. Discussions among ST, PSTC, WSDOT and regarding conducting a ‘load test’ to verify the adequacy of the bridge to handle light rail transit vehicle loading.
- 2004: Additional studies for Bus Rapid Transit (BRT) and Light Rail Transit (LRT) conversion and Monorail conversions along I-90 structures. Studies included conceptual design of structural modifications and preparation of construction cost estimates. WSDOT prepared scope of work for load test of floating bridge and engineering analysis of other structures along I-90 as well as study of monorail conversion.
- 2005: Additional discussions as documented in meeting notes
  - ST and WSDOT discussed design criteria assumed for feasibility study of conversion of I-90 floating bridge for Seattle Monorail Project operations.

- ST discussed LRT on I-90 floating bridge with Expert Review Panel.
- 2005: WSDOT completed load test for light rail transit on floating bridge in September 2005. KPFf issued *Homer Hadley (Interstate 90) Floating Bridge Test Program for Light Rail Transit Draft Test Report November 14, 2005*.

**Attachment B: SkyTrain Cable Stayed Bridge (Skybridge) Rail Joint – Additional Photos**



**Photo 3: Close up of the vertical movement mechanism of the rail joint**



**Photo 4: Close up of the bridge transition section**

**Attachment C: AREMA Technical Paper - *Design of Continuous Welded Rail on a Suspension Bridge*, 2000, Ranganatha R. Rao and Sudhir Sanghvi.**

# **DESIGN OF CONTINUOUS WELDED RAIL ON A SUSPENSION BRIDGE**

Technical Paper for AREMA

By: Ranganatha R. Rao\* and Sudhir Sanghvi\*\* – Parsons Transportation Group

---

\* Project Manager, Parsons Transportation Group

\*\* Project Engineer, Parsons Transportation Group

## **ABSTRACT**

This paper describes the challenging job of designing a 1.8 miles long continuous welded rail (CWR) on an existing suspension bridge over the River Tagus in Portugal. It also gives details of one of the world's largest rail expansion joints with a capacity of 60-inch movement, combined with the ability to disperse the angular rotation caused by the stiffening truss. The 7475 feet long continuous stiffening truss deflects 17 feet at the center of the bridge. The CWR is designed for such flexible support and for the resulting change in grades. In addition, the CWR also has to negotiate, at the bridge ends, significant angular bend caused by the behavior of the truss under railway loading.

The choice of various track components such as running rail, guard/check rail, low toe load fasteners, slide plates, etc., some of which are specially designed and/or modified for this bridge are illustrated and explained.

The dead load constraints and aerodynamic requirements dictated a design of open deck track for the railway deck. The track structure was kept independent of the longitudinal forces in the stringers, but had sufficient fixity to maintain the vertical and transverse constraints of the track against buckling.

The expansion assembly consists of moving telescopic girders mounted on vertical rollers and restrained by horizontal rollers between the stationary girders. Longitudinally split track rails are mounted on these girders. The construction work was completed in 1999.

## **INTRODUCTION**

The original suspension bridge over the Tagus River in Lisbon, Portugal was constructed in 1966. The design for the suspension bridge of this 7472 feet (2.3 km) long crossing was developed by Steinman Boynton Gronquist and London (Steinman). The main span is 3323 feet (1012.88 m), the side spans

are 1586 feet (483.42 m), and the three backstay spans are approximately 327 feet (100 m) each. The stiffening truss is 35 feet (10.65 m) deep. One of the unique features of this bridge is its 7472 feet long truss continuous over the suspended main, side and backstay spans. This was purposely designed to prevent large break in grade under train loading, which would have rendered the bridge otherwise unsuitable for future two-railway track installation. This resulted in one of the world's largest expansion joints at each end of the structure. The bridge was built to carry four lanes of highway traffic at the upper deck level with design provisions for a second phase construction to allow future railroad track installation at the bottom chord level.



**Photo #1 - Bridge Under Reconstruction**

## **INSTALLATION OF RAILWAY DECK**

In 1992, the Owners of this bridge awarded the design contract to add two railroad tracks at the lower level and to widen the upper deck to accommodate six highway lanes (see Figure 1).

The work was required to be performed with minimum interruption to the existing traffic. The original design provided for the second phase of construction to include the addition of new cable stays and installation of stringers at the lower level of the trusses for railway loading. Over the last 35 years there was a significant increase in the desired railway loading. The Portuguese National Railway (C.P. Rail) uses double decker passenger cars and freight cars known as mercadarios that produce live load much higher than that envisaged 30 years ago. Therefore, a comprehensive revised scheme of retrofitting had to be developed for railway load carrying capacity. After investigating several alternates, Steinman developed a system for adding new main suspension cables 3.7 m above the existing main cables. These new cables were to be anchored in new anchorages and supported at the existing towers on extended tower saddles.

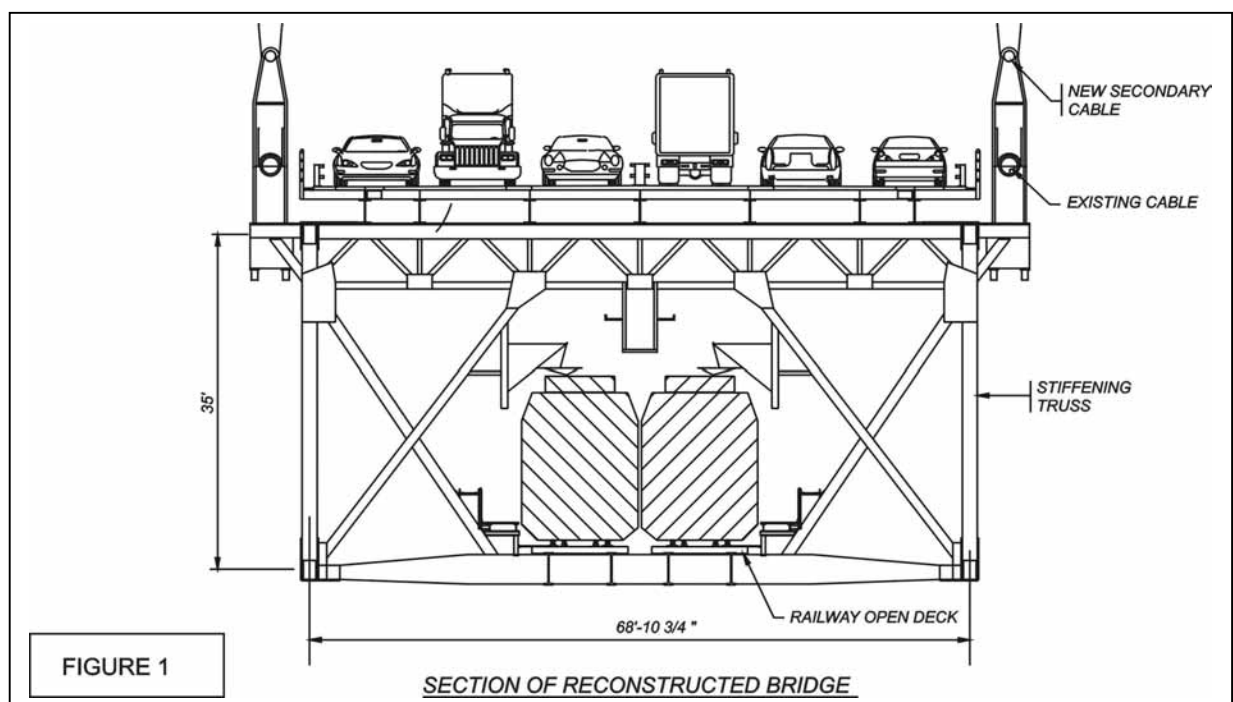

Figure 1 - Typical Cross Section of the Bridge

New cables are designed to carry all the new dead loads and participate in carrying some of the live load. The new suspenders are in four parts, located at alternate panel points (odd numbered panels), between the existing suspenders, which are located at even numbered panel points. With all dead load in place, the final bridge profile remained unchanged and the stiffening truss and the railroad stringers

stay unstressed under the influence of dead loads. One of the advantages in the present design of using external new main cable anchorages, in lieu of a proposed self-anchored system, is significant reduction in the size of track stringers (3'-4" feet deep rolled shapes). The new track stringers are framed into new floorbeams, all at the level of the bottom chords. The bottom horizontal frame consisting of stringers and floorbeams and lateral bracing are designed for the new additional live load. Additionally, some localized strengthening of other truss members (excluding bottom chord) was necessary.

The retrofitting consisted of the following:

- construction of new saddles above the existing ones on the two towers,
- construction of additional anchorages,
- spinning supplementary cables and installation of suspenders and transverse bracing,
- installation of new railway floorbeams, stringers and bracings,
- extension of roadway deck
- reinforcement of stiffening truss at certain locations,
- installation of double track and expansion assembly complex,
- installation of electric traction wires and signal systems and evacuation walkway.

This was a unique type of design and reconstruction of an existing suspension bridge, all done under uninterrupted traffic.

## **SELECTION OF TRACK**

The main considerations for the selection of track on a suspension bridge of this type are as follows:

- aerodynamically acceptable behavior,
- low dead load,
- independence from stresses in the truss,
- lower noise and maintenance levels,
- safety during derailment condition,
- capacity to accommodate a large expansion joint at ends.

After examining several alternatives such as steel ties, direct fixation, etc, continuous welded rails (CWR) with elastic fasteners on wooden ties at 23.6 inches (60 cm) spacing was considered as the best suited for this type of bridge. The track was designed to European Standards (U.I.C.) and for axle load of 50.4 kips (224 kn.) at 5.6 feet (1.7 m) spacing. The open deck was used in the section model for the wind tunnel testing and proved acceptable.

## **TRACK PROFILE AND GEOMETRY**

The bridge is constructed on a 2% grade on the north approach and a 0.75 percent grade on the south approach. The truss is built to a flat vertical curve with a theoretical dead load camber of 32.5 feet (9.9 m). The track profile is designed to follow the profile of the truss bottom chord. The new stringers are framed to provide a smooth profile and to avoid heavy shimming under the ties.

Because of the live load the truss deforms to cause a global profile change and a local change of grade below the concentrated loads. The design criteria for the reinforcement of the bridge were such that deflections are limited to provide for safe operation of trains. Change of grades not more than 0.12% at

the end of the truss for angular bend of the rail and any deflection at the intermediate points producing vertical curve not sharper than 13,124 feet (4000 m) radius, were the criteria considered adequate for a train speed of 38 mph (60 kmph).

The deflection curves produced by the computer model were studied to verify that these criteria were satisfied.

### TRUSS DEFLECTION MODES

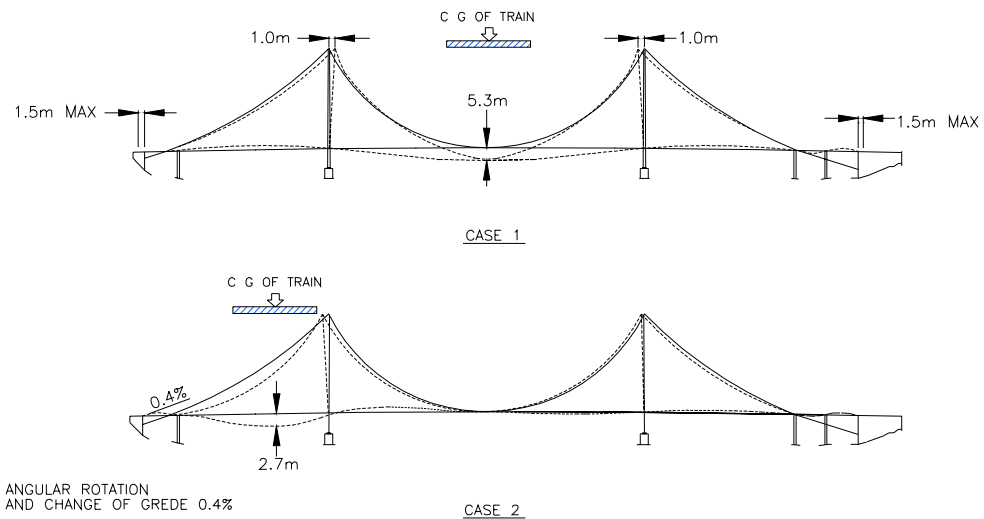

**FIGURE 2**



**Photo #2 - Deflection during passage of train**

## TRACK LAYOUT ON THE BRIDGE

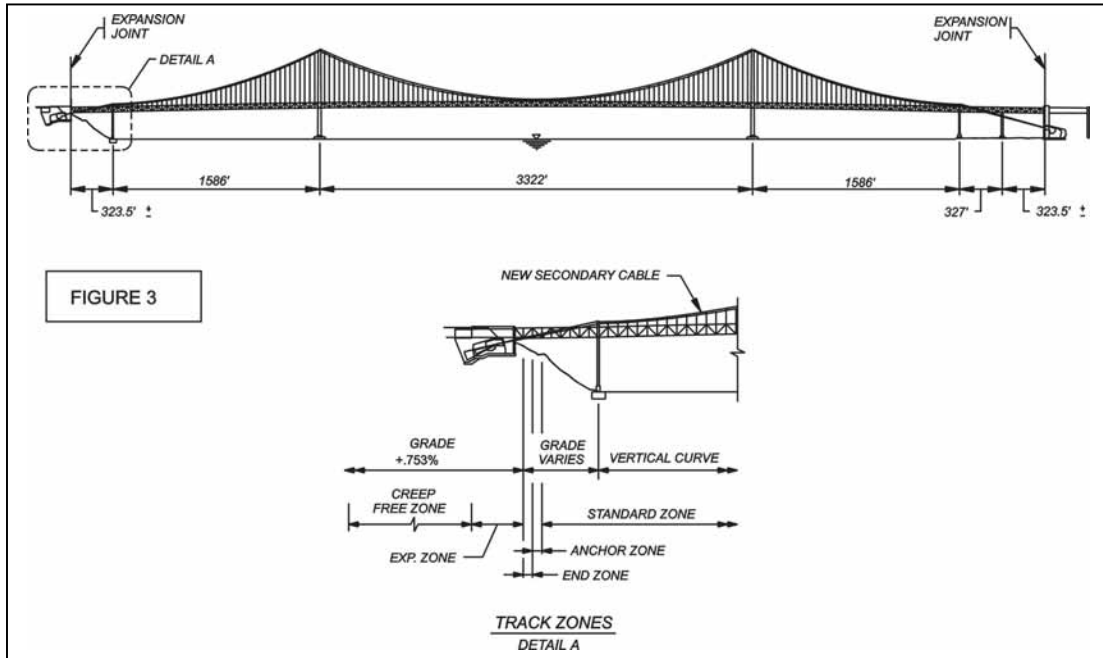

Figure 3 - Elevation of Tagus River Bridge

The track layout is divided into different zones on the 7472 feet length of the bridge as follows (see Figure 3):

- Standard Zone
- Anchor Zone
- End Zone
- Expansion Zone
- Creep Free Zone

The Standard Zone is also a rail slip zone, approximately 7050 feet (2.15 km) long, and consists of continuous welded rail. The track in this zone can flex to follow the different deflected shapes of the suspended truss as shown on Figure 2 (maximum deflection at center is 17.4 feet). The track is rigidly held transversely and vertically to the stringer for transfer of axle loads. The continuous rail can slip in its chairs longitudinally within the limits of the zone without picking up the axial forces of the stringer that supports it.

At the end of the Standard Zone the rail is anchored (anchor zone) to the stringer.

Anchor Zone - At either end of the bridge the CWR is terminated over a short length wherein the rail is anchored to the stringer through an anchor joint. The anchor joint is a specially designed insulated connection where in the rail is rigidly connected in the longitudinal direction but the rail is allowed the usual resilient support. This connection will provide the uniformity of the track modulus and prevent uneven wear of rail.

End Zone - This is a short stretch of track between anchor joint and start of expansion joint complex. Bonded rail at one end and insulated rail joint at the other end is provided for bypassing the track circuit over the expansion joint. This also provides the flexibility for construction and maintenance.

The continuous rail is ended (end zone) with a bonded joint. An insulated joint was also provided for a break in the track circuit, which is needed at the expansion ends.

Expansion Zone - The expansion zone accommodates the expansion complex. The expansion zone is kept free of CWR forces. Bonded rail joints are provided at each end for easy replacement of the expansion joint.

Creep Free Zone - In order to protect the expansion zone and to arrest any possible longitudinal movement, the creep free zone is provided with extensive creep anchors and an anchor joint on the approaches.

A detailed track chart was prepared for every panel of the bridge specifying the grade, elevation, rails; check rails, joints, ties, fittings, etc. An extract of the track chart at ends can be seen in Figure 4.

# TRACK CHART AT BRIDGE ENDS

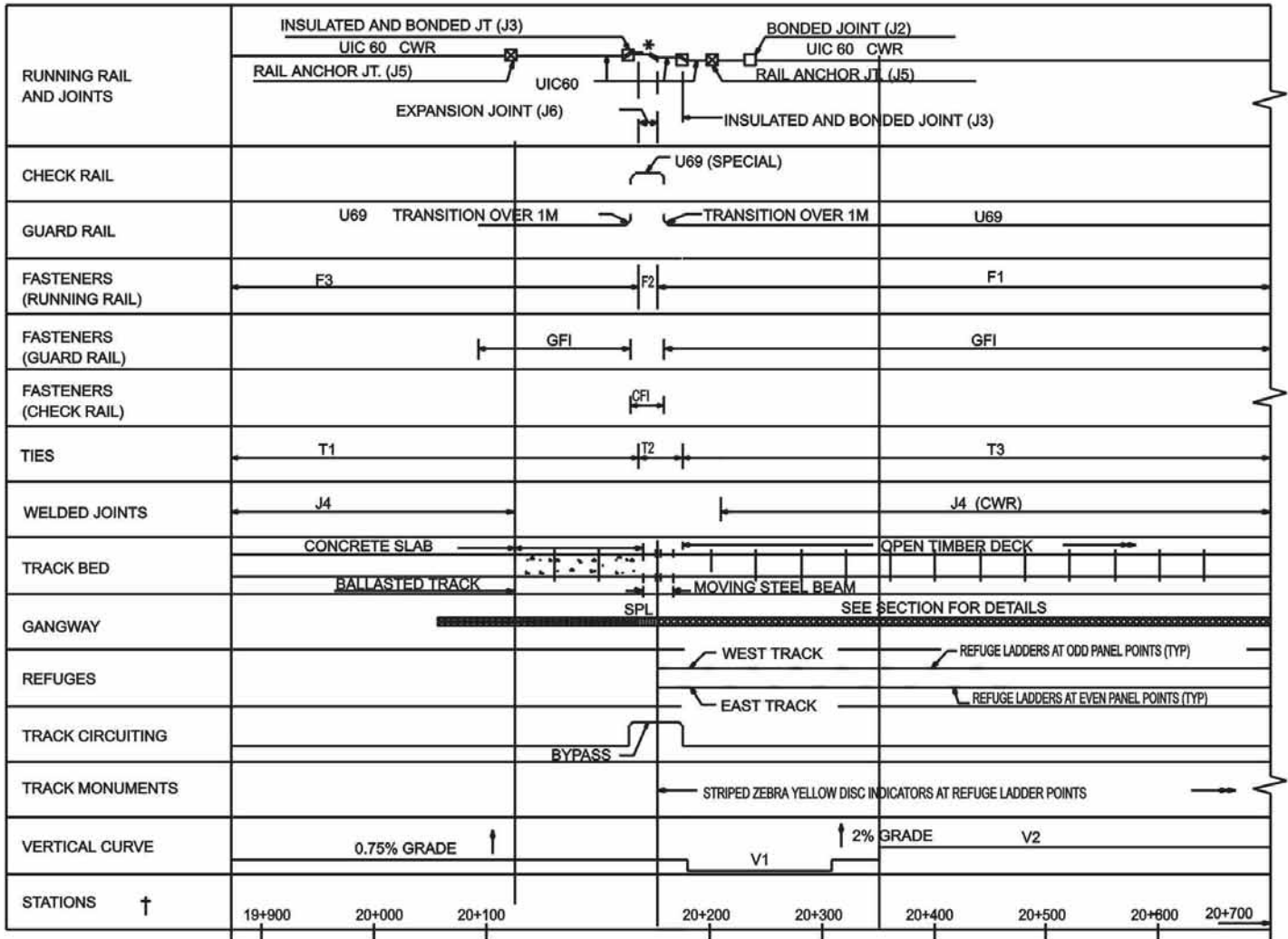

\* SPECIAL RAIL

↑ STATIONS ARE IN KILOMETERS + METERS

### LEGEND:

- |  |   |
|--|---|
| <p>T1 WOODEN TRACK TIES 250X150X2750</p> <p>T2 STEEL BEAM TIES (SEE DWG. NOS. T-15 AND T-16)</p> <p>T3 WOODEN BRIDGE TIES 250X150X3050</p> <p>F-1 RAIL FASTENER FOR DETAILS, SEE DWG. NO. T-11</p> <p>F-2 EXPN. RAIL FASTENER FOR DETAILS, SEE DWG. NO. T-19</p> <p>F-3 FOR FASTENER DETAILS, SEE TYPICAL SECTION FOR BALLASTED TRACK ON DWG. NO. T-20</p> | <p>GF1 GUARD RAIL FASTENER FOR DETAILS, SEE DWG. NO. T-11</p> <p>CF1 CHECK RAIL FASTENER FOR DETAILS, SEE DWG. NO. T-19</p> <p>J1-J6 RAIL JOINT DETAILS J1 TO J6, SEE DWG. NOS. T-14, T-21 AND T-22</p> <p>V1&amp;V2 FOR DETAILS OF VERTICAL CURVE, SEE DWG. NOS. T-2 AND T-3</p> |
|--|---|

FIGURE - 4

Figure 4 - An Extract of Track Chart at End

## TRACK SECTION AND COMPONENTS

The typical track section is as shown in Figure 5 below. Rail fixation details are illustrated in Figure 6.

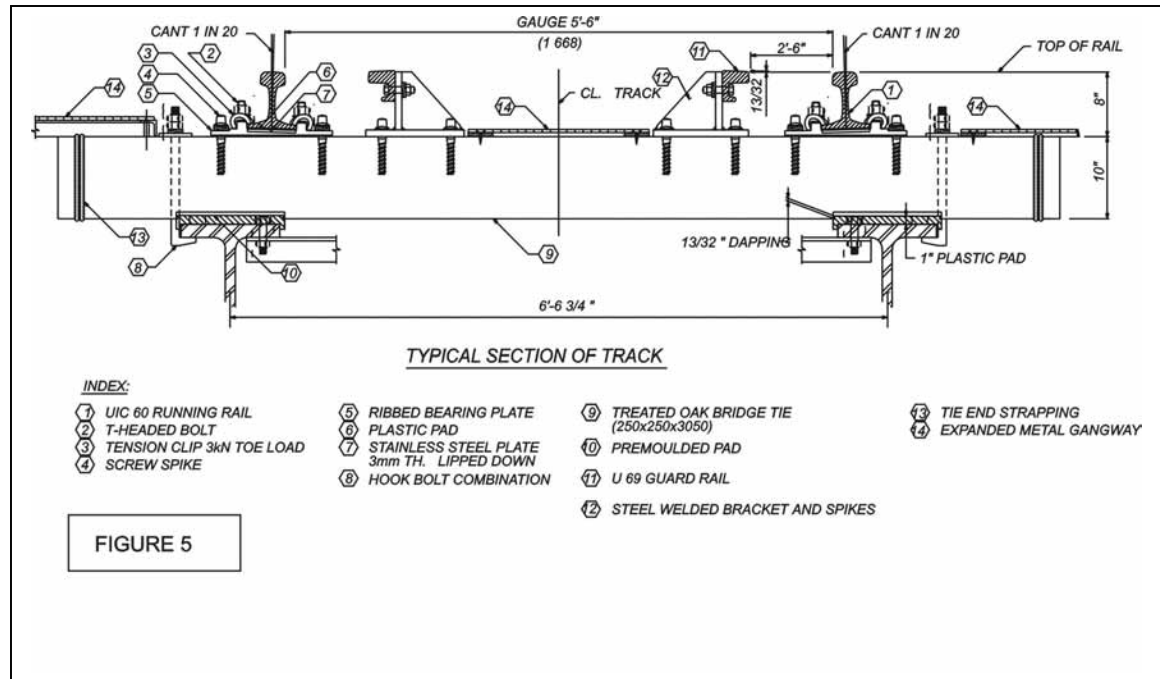

**Figure 5 - Typical Cross Section of Track on Suspension Span**

The track components are as follows:

### Running Rail (Mark 1)

As per the CP Rail practice UIC 60 (approximate equivalent - 120 lbs. rail) rail was used. The rail has an UTS of 160 ksi (1100 N/mm<sup>2</sup>). The rail, in sections of 38 feet (11.5 meters) was continuously welded over the entire length of the 7472 feet long truss.

### T-Headed Bolt (Mark 2)

The T-headed steel bolt fits into the slot in the ribbed bearing plate, keeping the tension clip in place and inducing appropriate preload in the rail.

### Tension Clip (Mark 3)

The design and selection of the tension clip is a salient characteristic of this track. The rail needs to adjust to the deflection of the long stiffening truss as the truss deforms under live load. The rail does that by slipping longitudinally. Therefore, a new clip was developed, by modifying the standard SKL-12 clip, as manufactured by Vossloh of Germany. The modified clip induced a low toe load of 675 lbs. (3 kN) instead of the standard toe load of 2.9 kips (13 kN). The modified clip has the added advantage of a partial *rail free type* fastener, which allows the rail to slide longitudinally on its chair. As a result, the running rail stresses remain independent of the rail stringer stresses. Further, to facilitate sliding, a 3-mm stainless steel plate (Mark 7) is provided underneath the rail. The clips provide restraints in two stages (see Figure 7).

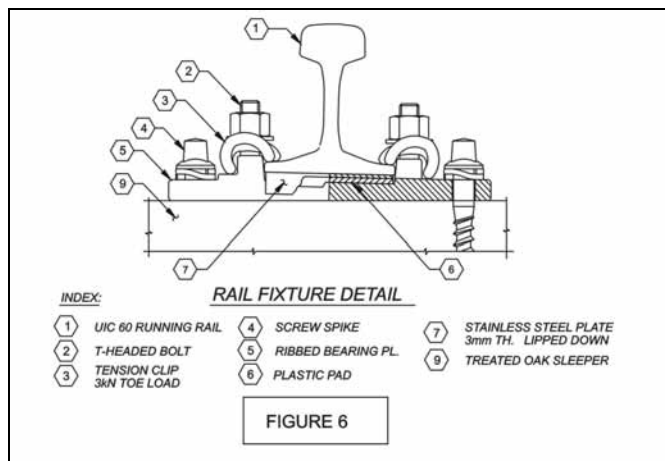

Figure 6 - Limited rail fixation and sliding arrangement

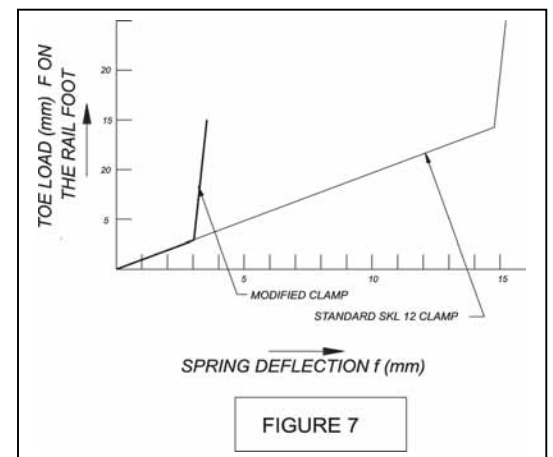

Figure 7 - Tension Clip Characteristics

### Screw Spikes (Mark 4)

The spikes are in conformance to UIC Standards, however split washers were provided to reduce the possibility of spikes getting loose under repetitive lateral loads and also reducing the probability of fibers of oak ties being damaged under such repetitive lateral loads.

### Bearing Plate (Mark 5)

These cast steel ribbed bearing plates have a cant of 1 in 20 and have slots in the ribs to engage the T-headed bolts.

### Plastic Pads (Mark 6)

Premolded plastic pads made by Getzner of Austria under the trade name of Sylomer 800 were adopted for placement underneath the ties. The structural design of the stringers and floorbeams are such that the connections and splices provided an uneven seating for the placement of the ties. Notches in the ties to accommodate bolt heads were ruled out as dead load limitations on the bridge governed the design depth of the ties. Instead, perforated plastic pads were used, to provide an even seating. These perforations in the pads eliminated the ridges created by the bolt heads in the areas of spliced connection. In accordance with the recommendation of the manufacturer of the pads, a preload of 6 kN was applied through the hook bolts to maintain the pads under load. The pads also reduce the noise level on the track.

### Oak Ties (Mark 9)

Unconventionally, the bridge timbers were designed for 50.4 kips (224 kN) axle load based on Talbot's theory of track behavior and design. The oak ties, impregnated with creosote, are 10 inches square (250 x 250 mm) in cross-section and 10 feet (3 m) long at 2 feet (60 cm) spacing. As stated before, to limit dead load on the bridge, the most economical depth of ties was used. Except for  $\frac{7}{16}$  inch (10 mm) dapping, no notching of any kind was permitted which would lower the effective depth of the sleeper.



**Photo #3 - Hook Bolt, Tension Clip and Clip Fixation**



**Photo #4 - Hook Bolt and Plastic Pad as seen from bottom**

### Hook Bolts (Mark 8)

Unlike the common practice in Europe, hook bolts were adopted for engaging the oak ties with the stringers. The hook bolts, with a directional notch on the top were installed with double nuts. Provision of plastic pads below the ties result in deflection of ties under axle loads. In order to maintain a hold down force on the ties, spring washers were introduced below the nut with a nominal preload.

### **EXPANSION ASSEMBLY COMPLEX**

The suspension bridge truss is comparatively a flexible structure. The railway loading consisting of heavy concentrated loads, when moving on this flexible bridge causes local and global deformation (deflection) of the truss. The railway track experiences steep grades and changes of grades at the center and specifically at the ends of truss. This has a significant effect at the end producing an angular bend in the rail.

### The Behavior of the Bridge at the Ends

The Tagus River Bridge has one of the world's longest continuous stiffening girders, 7472 feet long continuous structure. The thermal expansion of the trusses is significant at the ends. In addition, the truss ends also move in and out due to deflection of the truss under the live load depending on the

location of the load. The maximum calculated movement at the ends for the design was 60 inches (1500 mm). It is interesting to observe the end of the bridge to move visually a few centimeters a second, as a heavy load moves from end to end.

If the running rail, is rigidly fixed to the end stringer and the transition girder, will result in a kink in the rail and high bending and fatigue stresses. (see Figure 8). Therefore the rail is mounted on resilient chairs capable of allowing the rail base to rise and fall to adjust for the imposed curvature (see elevation and rail profile in figure 8). Handling of the constant cyclical longitudinal movements (up to 60 inches max.) and the angular bends in running rail is a complex problem with respect to railway track, which was resolved by designing a unique expansion assembly complex.

## **EXPANSION ASSEMBLY**

This is one of the largest and most complex expansion assemblies in the world. The expansion system is a combination of appurtenances located at either end of the bridge. This expansion assembly was especially developed to address the existing conditions such as restricted space, high expansion range and construction of the unit under traffic conditions on an existing bridge. After extensive research, including studying the existing joints in other parts of the world, this split rail type of expansion joint was developed. During the preliminary design stage other alternatives such as switch type expansion joints, moving sleeper type, etc., were investigated. These types required large space at the end of the bridges. Their large number of moving parts requires constant maintenance. Considering the limited space available at the end of this existing bridge, the telescopic girder type was selected as the most suitable (see Figure 9). This expansion joint is unique in that two functions, such as longitudinal movement and dispersion of angular bend, have been accommodated in a limited space of 28 feet (8.5 m). It is the most compact, yet one of the largest expansion joints in the world.

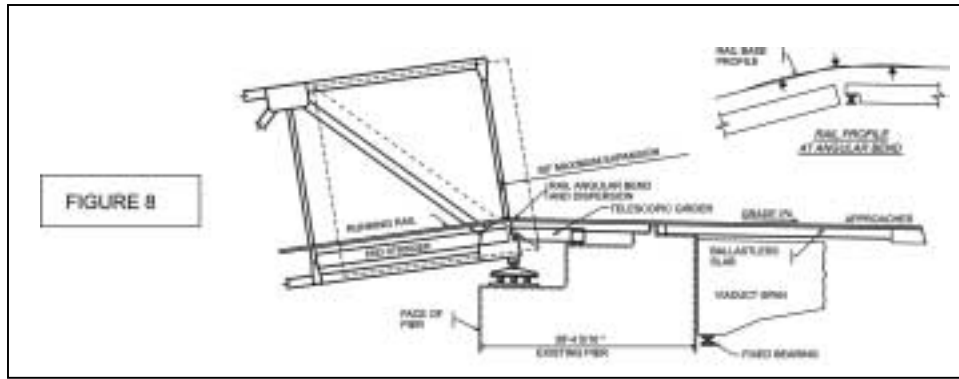

**Figure 8 - Angular Rotation and Expansion at Ends**

The expansion assembly complex consists of the following important components:

- Transition girder and telescopic girders
- Split rails for rail expansion
- Check rail and its expansion arrangements
- Angular bend dispersion components
- Telescopic girder mountings

### Transition Girder

In order to cover the expansion gap of 5 feet (max.) at the ends (see Figure 8) and to flex for the angular bend, a short, 20 feet (6 m) transition girder was designed. This also acts as the inner moving telescopic girders for expansion. This girder, which is unique in this design, accomplishes two functions. This girder is supported at one end on a hinged bearing over the end floorbeam. The other end is supported on rollers, which roll on a track beam (see Figure 9).

The moving telescopic girder (transition girder) is inserted between the two stationary telescopic girders (see Figure 10) and held laterally and rigidly by two horizontal rollers (see Figures 10 and 11) with a preload force of 22.5 kips (100 kN) in order to maintain clearance of ¼ inch (6 mm) between

stationary and moving girders. These girders are designed very stiff, structurally, to limit deflections to no more than 1 mm.

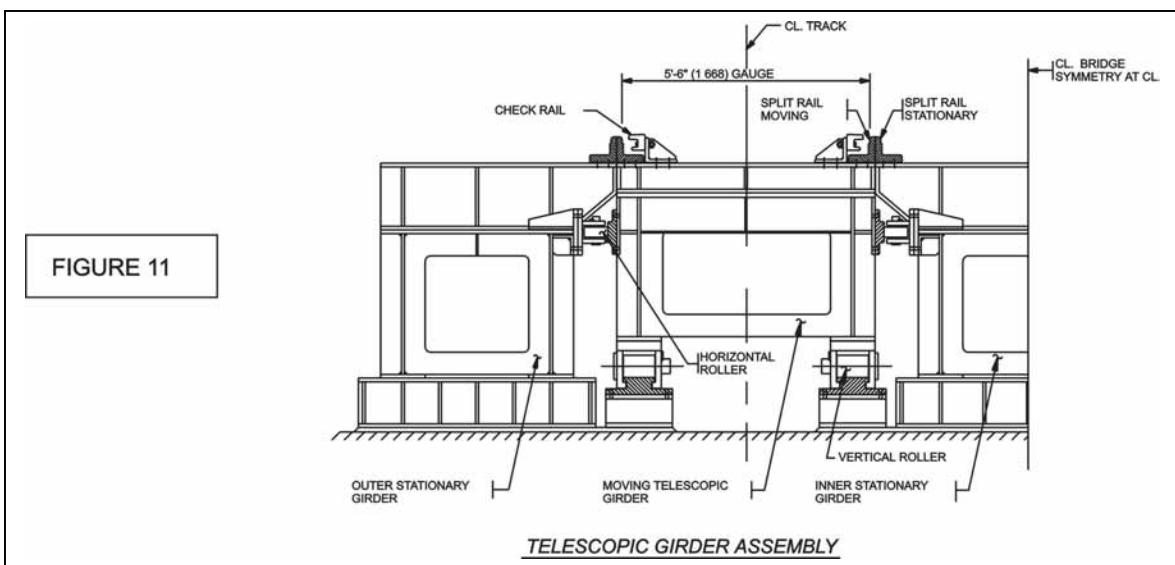
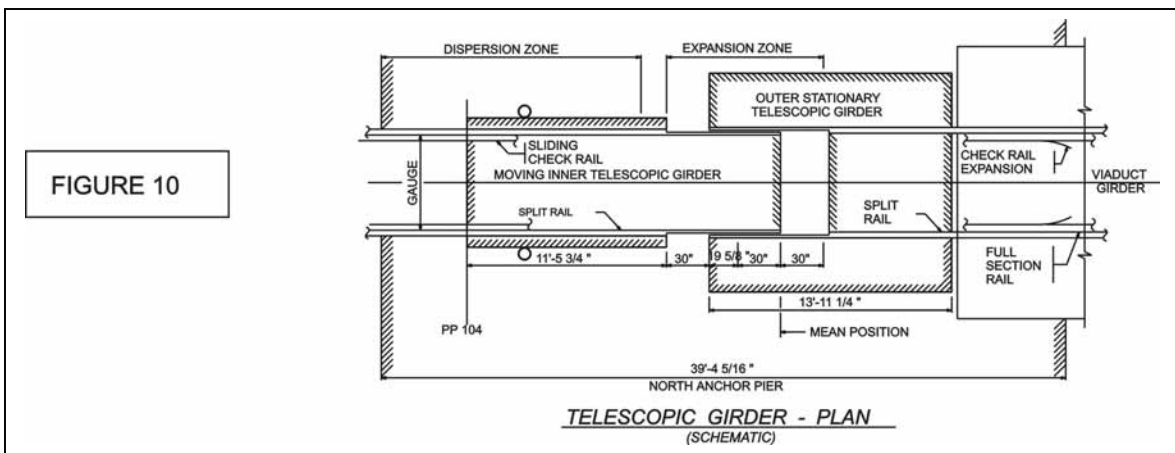
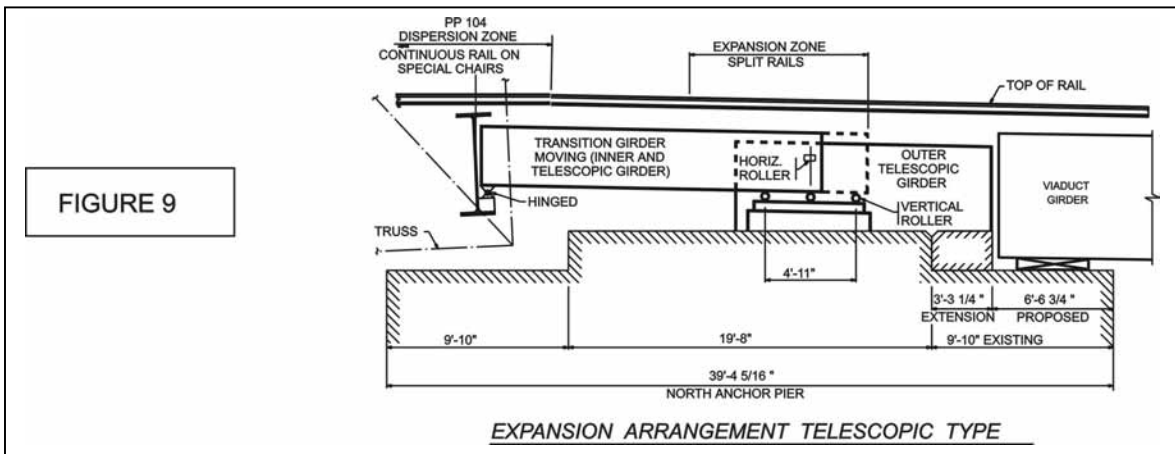

## Split Rails

These L-shaped rails have a top profile of UIC-60 railhead as detailed in Figure 12, Section E. The split rails are made of high-manganese steel, forged and surface-hardened in fine laminated perlite structure to a level of 167 ksi (1150 N/mm<sup>2</sup>) for a depth of 1 inch (25 mm) for wear resistance. The split rails are mounted on the stationary and moving girders back to back with a clearance of 2 mm as indicated in Section C. The tip of the rail, facing the direction of traffic is specially shaped to transfer the rolling wheel contact smoothly to the adjacent split rail. The wheel-rail interaction and the wheel load transfer over the split rail are illustrated in Figure 12. In order to control and guide the wheel to roll at the gauge face, a U69 type high performance rolled steel check rail is placed at 1¾ inches (45-mm) clearance. With the presence of this laterally stiff continuous check rail at the wide gauge zone of single split rail (see Figure 12, Section F), the wheel is ensured of safe rolling at the correct alignment. (See Figure 12, Plan View). The design assumptions, the actual dynamic effects of the wheel over the expansion joint and the adequacy of the various clearances were verified by prototype testing.

## Check Rail Expansion

The check rail is kept continuous over the expansion gap. It is extended continuously from the truss over the telescopic girder and expansion joint up to the approaches to provide lateral restraint to the wheel flange. The checkrails on the stationary girders have been mounted on slide chairs designed for full lateral forces of the wheel, (see Figure 12, Section G). The check rail is provided with an expansion arrangement on the approaches.

# RAIL WHEEL INTERACTION OVER SPLIT RAIL

# SPLIT RAIL ASSEMBLY

## PLAN VIEW

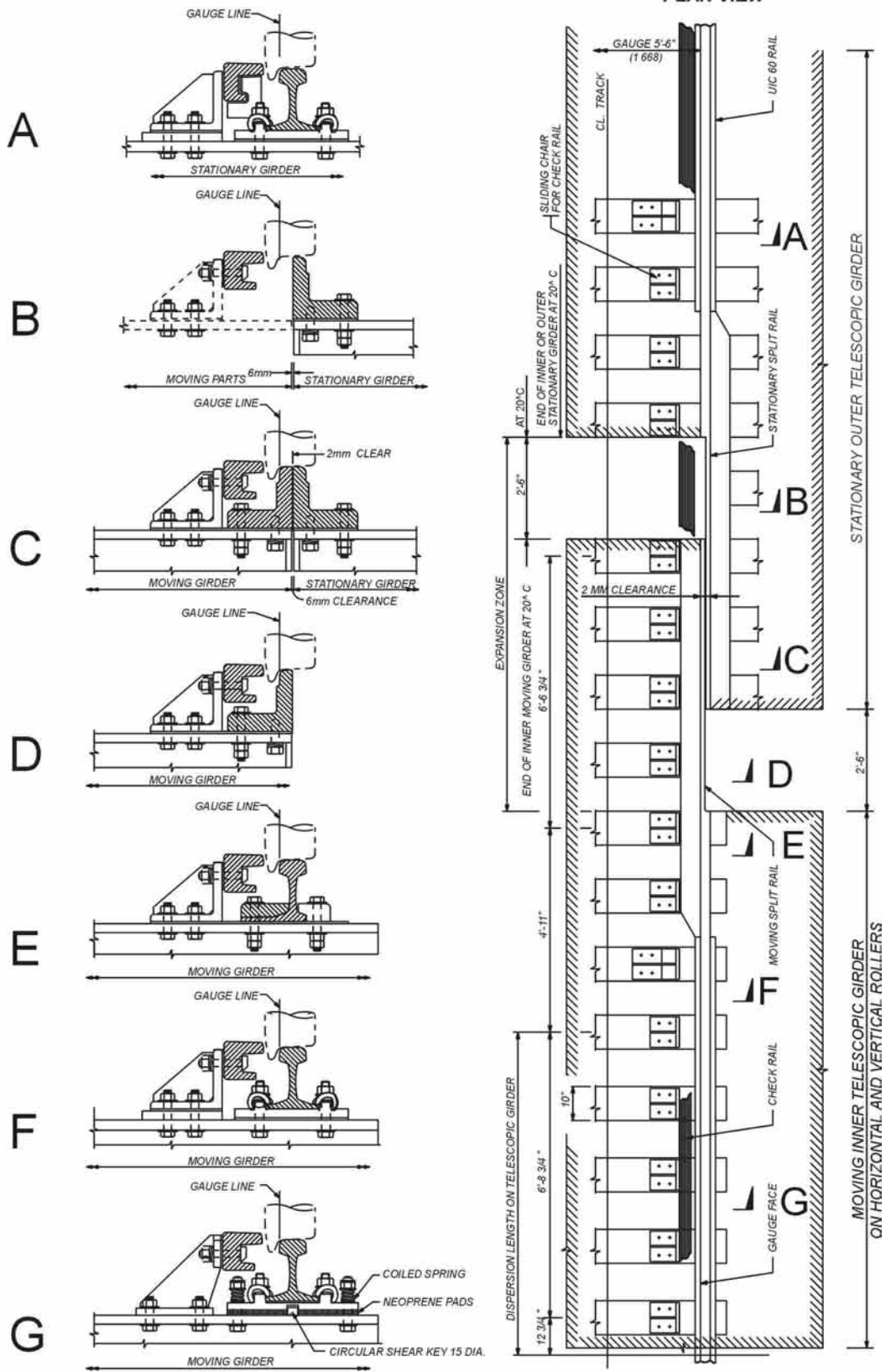

FIGURE - 12

### Angular Bend Dispersion Components

In order to uniformly distribute the angular bend of maximum 0.06 radian and permit the rail to assume a curvature, concave or convex, the rail is fixed on special type of chairs. A dispersion length of 81 inches (2052 mm) was considered sufficient on the transition girder and similarly on the end stringer. Four chairs to the details shown in Figure 12, Section G, were designed and installed at each dispersion length.

These chairs consist of steel bearing plate mounted on a combination bearing pads, which were designed to produce compound deflection characteristics. Instead of the coil springs shown, the Contractor preferred to provide disk springs that produced the complimentary spring characteristics of the combination bearing pad.

The bearing plate supporting the rail base on an elastic fastener can rise and fall up to 2 mm under the wheel load as well as to the varying conditions of the rail curvature. Satisfactory functioning of these chairs was verified in dynamic testing conducted in Germany.

### **OTHER MOUNTINGS IN EXPANSION ASSEMBLY**

The horizontal rollers are mounted on the stationary girders. They consist of 4.7 inches (120 mm) diameter steel rollers with bronze bush bearings (see Figure 11). They are designed for 45 kips (200 kN) lateral loads. A pack of disc springs apply a constant preload of 22.5 kips (100 kN) on these horizontal rollers which keep the telescopic girder laterally rigid so as to maintain the 2 mm clearance between moving split rail and stationary split rail.

The vertical steel rollers on the bronze bearings are mounted at the bottom of the telescopic girder at the far end (See Figure 11). They are designed for DL, LL and I and to roll for constant cyclical longitudinal movement of the telescopic girder. The steel assemblies in which the rollers are housed

are designed with close tolerance to resist lateral forces and uplift forces caused by the passage of wheel loads. These rollers are critical in maintaining the gauge and close clearances in the split rail.

## **TESTING**

It was specified in the contract that a prototype expansion joint must be load tested with test train to study its behavior, prior to the installation of the joint on the bridge. Test criteria were also identified in the Contract Specifications. Test results were to be evaluated and if necessary, fabrication details were to be modified.

### **Prototype Testing**

Prototype testing was split into two phases, namely, "Workshop Test" and "Field Test." The Workshop Test evaluated the behavior of the expansion joint under a longitudinal movement and the angular rotation, with different load positions. The test load consisted of two-axle bogie loaded with an high speed extenter (eccentric wheel) inducing eccentric loading, which simulated the dynamic effects a running train. The Field Test was aimed at testing the rail-wheel interaction on the expansion joint with the joint set in the maximum open position. The field test also shed light on the performance of the check rails, derailment effects, rail-wheel contact area condition and stresses and deflection under running wheel.

### **Workshop Testing**

The workshop test was conducted at the Contractor's site in Gotha, Germany. The workshop testing consisted of mounting the expansion joint consisting of telescopic girders and the split rails over a steel frame. The thermal expansion and the angular rotation were simulated by a set of horizontal and vertical hydraulic rams, which induced the reciprocating motion on the joint and the extenter attempted to simulate the wheel dynamic effects. This set up provided enough test data to study the behavior of

different moving parts. The workshop test endorsed the design parameters with some minor improvements. The following observations and/or improvements were made:

1. The rail stress due to angular bend was much less than the design load.
2. The combination pads provided under the rail chairs at the dispersion zone behaved as designed.
3. The horizontal and vertical roller functioned as designed. However, some improvements in lubrication were added.
4. The rotational bearing needed minor adjustments.
5. The rail joint at the end of dispersion zone was provided with a larger bolt hole.



**Photo #5 - Dynamic testing of Expansion Joint at Shop**

### Field Testing

The field test was conducted in Portugal for two weeks with a test train of three diesel-electric, six axle locomotives, (21.5 tonnes of axle load) two hopper-ballast wagons and one tank wagon with a total weight of about 525 metric tonnes. The test speed was 60 kmph and the total number of train passages was 2500 cycles.

The deflection and stress measurements were accomplished by electric sensors, observed on a display after each measured overrolling. The rail wear was measured by observing the contact area by recording the change in the width of the "polished zone" at the rail head.

The field test measurements indicated that:

- The rail stresses were well within the allowable fatigue strength of UIC 60 rail
- The maximum rail-wheel contact (shear) stresses in the outer split rail, as determined from the measured contact area was  $245 \text{ N/mm}^2$ , (35 ksi) 30% lower than the allowable fatigue shear strength of  $315 \text{ N/mm}^2$  (45 ksi).
- The horizontal deflections of the split rails (1.0 mm average for the inner and outer split rail) was found to be not critical and the derailment quotient  $Q_h/Q_v$  was far below 0.7, established during the static calibrations in the Workshop Test.
- The contact area remained almost constant during the 2500 test runs.



**Photo # 6 (left) - Field Test Set Up**

Reports on test results indicated, aside from some minor modifications, the expansion joint behaved as designed.

## **SYNOPSIS**

Double track of continuously welded rail and expansion joint units has been successfully installed and after completion of the required testing the bridge has been officially opened to traffic since July, 1999 (see Photograph below).



**Photo # 7 - View of Double Track at Ends**

## **ACKNOWLEDGEMENT**

The entire project has been developed under the direction of REFER (formally GECAF) of Portugal (Mario Fernandes, Director, Luis do Canto Moniz, Chief Engineer), and the authors are grateful for their assistance and direction in the successful completion of this project.